



S6 Master Module

Models M10 and M40

Legal Notices

© 2014 Avid Technology, Inc., ("Avid"), all rights reserved. This guide may not be duplicated in whole or in part without the written consent of Avid.

003, 192 Digital I/O, 192 I/O, 96 I/O, 96i I/O, Adrenaline, AirSpeed, ALEX, Alienbrain, AME, AniMatte, Archive, Archive II, Assistant Station, AudioPages, AudioStation, AutoLoop, AutoSync, Avid, Avid Active, Avid Advanced Response, Avid DNA, Avid DNxcel, Avid DNxHD, Avid DS Assist Station, Avid Ignite, Avid Liquid, Avid Media Engine, Avid Media Processor, Avid MEDIArray, Avid Mojo, Avid Remote Response, Avid Unity, Avid Unity ISIS, Avid VideoRAID, AvidRAID, AvidShare, AVIDStripe, AVX, Beat Detective, Beauty Without The Bandwidth, Beyond Reality, BF Essentials, Bomb Factory, Bruno, C|24, CaptureManager, ChromaCurve, ChromaWheel, Cineractive Engine, Cineractive Player, Cineractive Viewer, Color Conductor, Command8, Controll24, Cosmonaut Voice, Countdown, d2, d3, DAE, D-Command, D-Control, Deko, DekoCast, D-Fi, D-fx, Digi 002, Digi 003, DigiBase, Digidesign, Digidesign Audio Engine, Digidesign Development Partners, Digidesign Intelligent Noise Reduction, Digidesign TDM Bus, DigiLink, DigiMeter, DigiPanner, DigiProNet, DigiRack, DigiSerial, DigiSnake, DigiSystem, Digital Choreography, Digital Nonlinear Accelerator, DigiTest, DigiTranslator, DigiWear, DINR, DNxchange, Do More, DPP-1, D-Show, DSP Manager, DS-StorageCalc, DV Toolkit, DVD Complete, D-Verb, Eleven, EM, Euphonix, EUCON, EveryPhase, Expander, ExpertRender, Fairchild, FastBreak, Fast Track, Film Cutter, FilmScribe, Flexevent, FluidMotion, Frame Chase, FXDeko, HD Core, HD Process, HDpack, Home-to-Hollywood, HyperSPACE, HyperSPACE HDCAM, iKnowledge, Impact, Improv, iNEWS, iNEWS Assign, iNEWS ControlAir, InGame, Instantwrite, Instinct, Intelligent Content Management, Intelligent Digital Actor Technology, IntelliRender, Intelli-Sat, Intelli-Sat Broadcasting Recording Manager, InterFX, Interplay, inTONE, Intraframe, iS Expander, iS9, iS18, iS23, iS36, ISIS, IsoSync, LaunchPad, LeaderPlus, LFX, Lightning, Link & Sync, ListSync, LKT-200, Lo-Fi, MachineControl, Magic Mask, Make Anything Hollywood, make manage move|media, Marquee, MassivePack, MassivePack Pro, Maxim, Mbox, Media Composer, MediaFlow, MediaLog, MediaMix, Media Reader, Media Recorder, MEDIArray, MediaServer, MediaShare, MetaFuze, MetaSync, MIDI I/O, Mix Rack, Moviestar, MultiShell, NaturalMatch, NewsCutter, NewsView, NewsVision, Nitris, NL3D, NLP, NSDOS, NSWIN, OMF, OMF Interchange, OMM, OnDVD, Open Media Framework, Open Media Management, Painterly Effects, Palladium, Personal Q, PET, Podcast Factory, PowerSwap, PRE, ProControl, ProEncode, Profiler, Pro Tools, Pro Tools|HD, Pro Tools LE, Pro Tools M-Powered, Pro Transfer, QuickPunch, QuietDrive, Realtime Motion Synthesis, Recti-Fi, Reel Tape Delay, Reel Tape Flanger, Reel Tape Saturation, Reprise, Res Rocket Surfer, Reso, RetroLoop, Reverb One, ReVibe, Revolution, rS9, rS18, RTAS, Salesview, Sci-Fi, Scorch, ScriptSync, SecureProductionEnvironment, Shape-to-Shape, ShuttleCase, Sibelius, SimulPlay, SimulRecord, Slightly Rude Compressor, Smack!, Soft SampleCell, Soft-Clip Limiter, SoundReplacer, SPACE, SPACESHift, SpectraGraph, SpectraMatte, SteadyGlide, Streamfactory, Streamgenie, StreamRAID, SubCap, Sundance, Sundance Digital, SurroundScope, Symphony, SYNC HD, SYNC I/O, Synchronic, SynchroScope, Syntax, TDM FlexCable, TechFlix, Tel-Ray, Thunder, TimeLiner, Titansync, Titan, TL Aggro, TL AutoPan, TL Drum Rehab, TL Everyphase, TL Fauxlder, TL In Tune, TL MasterMeter, TL Metro, TL Space, TL Utilities, tools for storytellers, Transit, TransJammer, Trillium Lane Labs, TruTouch, UnityRAID, Vari-Fi, Video the Web Way, VideoRAID, VideoSPACE, VTEM, Work-N-Play, Xdeck, X-Form, and XMON are either registered trademarks or trademarks of Avid Technology, Inc. in the United States and/or other countries.

Bonjour, the Bonjour logo, and the Bonjour symbol are trademarks of Apple Computer, Inc.

Thunderbolt and the Thunderbolt logo are trademarks of Intel Corporation in the U.S. and/or other countries.

This product may be protected by one or more U.S. and non-U.S. patents. Details are available at www.avid.com/patents.

Product features, specifications, system requirements, and availability are subject to change without notice.

Guide Part Number 9329-65269-00 REV B 06/14

Contents

- Chapter 1. Introduction** 1
 - Module Capabilities and Features 2
 - System Requirements and Compatibility 2
 - Registration 2
 - About www.avid.com 2

- Chapter 2. S6 Master Module Connections** 3
 - Connecting a Single Module 3

- Chapter 3. S6 Master Module Overview** 4
 - Back Panel 5
 - Side Panel 5
 - Top Panel Controls and Displays 6

- Appendix A. Specifications** 13
 - Mechanical 13
 - Environmental 13
 - Dimensions 14

- Appendix B. Compliance Information** 15
 - Environmental Compliance 15
 - EMC (Electromagnetic Compliance) 16
 - Safety Compliance 17

Chapter 1: Introduction

The Avid® S6 Master Module is a central control module with a Touchscreen surrounded by various controls and displays.

There are two models of the Master Module, the M10, and M40. Both versions provide the same Touchscreen, controls, connectors and features. The only differences between the two models are the number and type of modules they support, and the number of workstations that can be connected simultaneously:

M10 Communicates with up to 10 other modules. Does not support Display Modules.

M40 Communicates with up to 40 other modules and can connect to Display Modules.

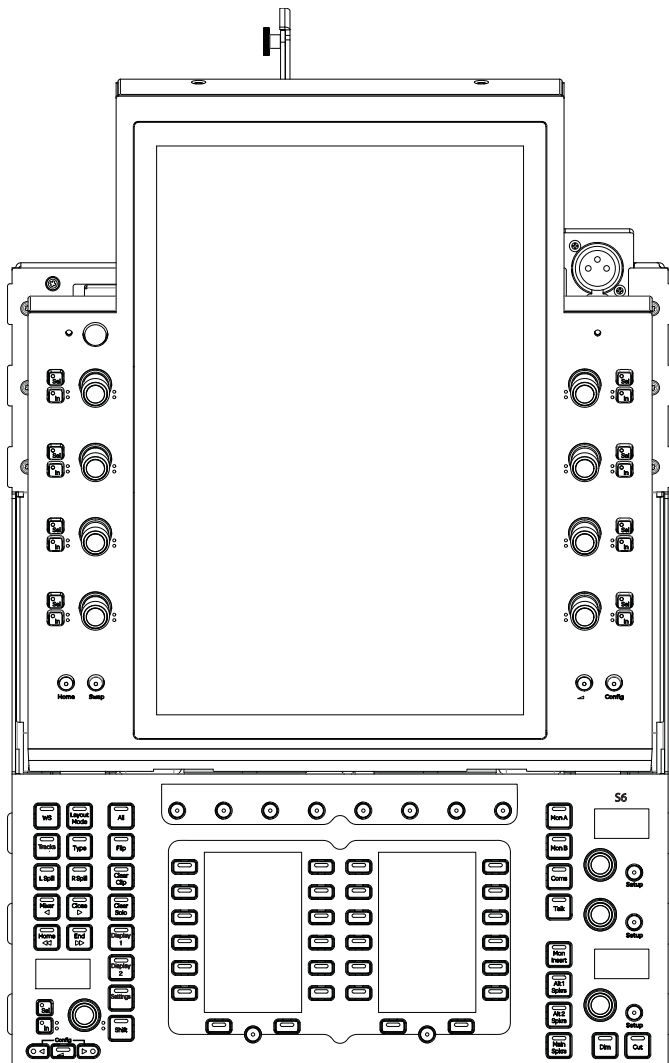

Master Module

Module Capabilities and Features

- 1280 x 800 TFT multi-point Touchscreen, surround by 8 knob cells
- Home/Navigation switches
- Soft Keys and display
- Main Menu switches
- Custom knob
- Studio/Talk controls and display
- Main Monitor controls and display
- Setup keys
- 2-pin 12V Power
- 6 (six) USB ports
- 2 (two) XLR connectors
- 1 (one) D-Type connector for GPI input and output
- 3 (three) 1000-BaseT (Gigabit) Ethernet RJ45 connectors

System Requirements and Compatibility

Avid can only assure compatibility and provide support for hardware and software it has tested and approved.

For complete system requirements and a list of qualified computers, operating systems, hard drives, and third-party devices, visit: www.avid.com/compatibility

Registration

Review the enclosed Registration Information Card and follow the instructions on it to register your purchase online.

By registering, you become eligible to receive the following:

- Information regarding technical support
- Software update and upgrade notices
- Limited warranty on hardware

Hardware Warranty

Your warranty can be found on the Registration Information Card.

About www.avid.com

The Avid website (www.avid.com) is your best online source for information to help you get the most out of your Pro Tools system. The following are just a few of the services and features available.

Product Registration Register your purchase online.

Support and Downloads Contact Avid Customer Success (technical support); download software updates and the latest online manuals; browse the Compatibility documents for system requirements; search the online Knowledge Base or join the worldwide Pro Tools community on the User Conference.

Training and Education Study on your own using courses available online or find out how you can learn in a classroom setting at a certified Pro Tools training center.

Products and Developers Learn about Avid products; download demo software or learn about our Development Partners and their plug-ins, applications, and hardware.

News and Events Get the latest news from Avid or sign up for a Pro Tools demo.

Chapter 2: S6 Master Module Connections

Connecting a Single Module

Connectors for power and primary Ethernet are located along the side of the module.

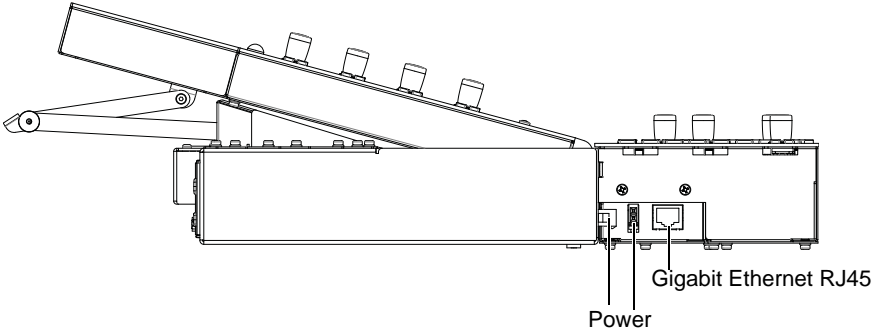

Additional Ethernet ports are provided on the back panel. If you already have a DHCP Server on your network, connect a second Ethernet cable to Ethernet port **1** on the back panel of the Master Module. If you do not have a DHCP Server on your network connect a second Ethernet cable to back panel Ethernet port **2**.

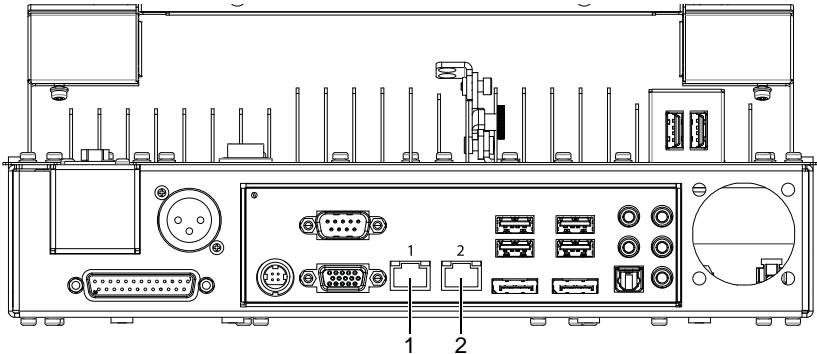

The Master Module is powered by 12 V DC. The power input connectors (two) are 2-conductor Molex.

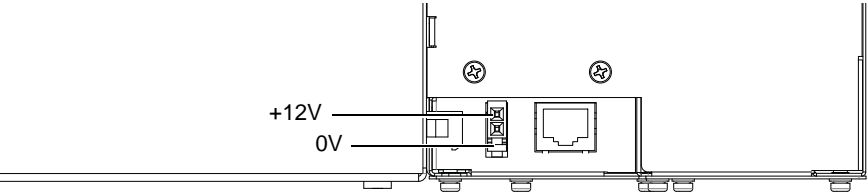

Chapter 3: S6 Master Module Overview

This chapter identifies the hardware features on the Master Module.

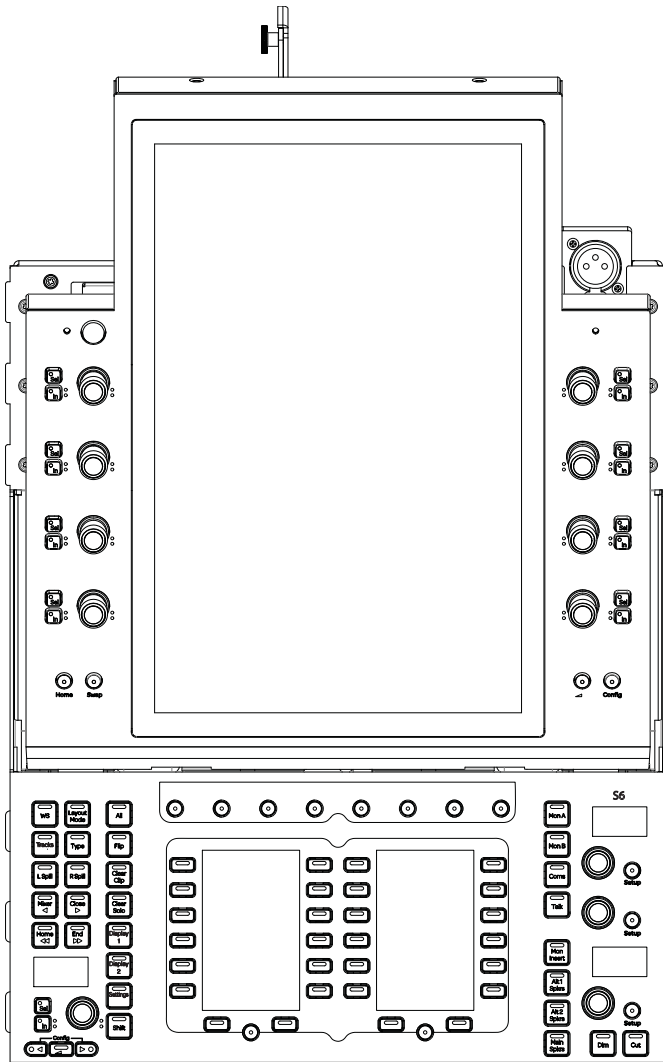

Master Module

The Master Module is a master section module used for system control.

The upper part the Master Module features a 12.1-inch multi-touch screen with eight adjacent knobs, which control virtual knobs on the screen. The upper part of the Master Module can be tilted and secured into position to achieve the best viewing angle. The lower part of the Master Module features two sets of Soft Keys, dedicated knobs and switches for monitoring and other functions, and a section to control global system parameters and settings.

Back Panel

The back panel of the Master Module provides connectors for USB, Talkback, GPI and other signals as described below. Not all connectors are implemented.

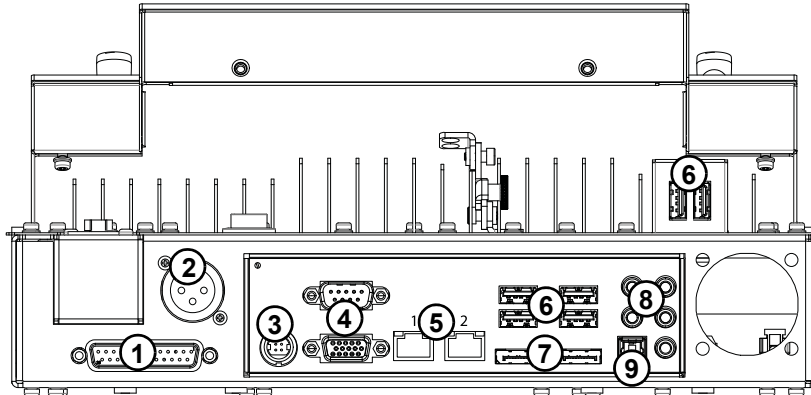

Back panel of the Master Module

1 – GPI I/O (Unused)

- 1 (one) 25-pin D-Sub providing 8 channels of GPI input and 8 channels of GPI output. This port is not yet supported.

2 – Talkback Thru

- 1 (one) XLR-M for audio Talkback output/pass-thru (Talkback input is located on the top panel).

3 – DC IN (Unused)

- This 4-pin port is for manufacturing, diagnostics and troubleshooting only, and should not be used.

4 – COM and VGA (Unused)

- These ports are for manufacturing, diagnostics and troubleshooting only, and should not be used.

5 – Ethernet

- 2 (two) 1000-BaseT (Gigabit) Ethernet ports. Use only one of these two ports (1 or 2, depending on the type of network to which you are connected). Use port **1** if you are connecting to a DHCP server; otherwise, use port **2**.

6 – USB

- 2 (two) USB ports on the top/back of the Touchscreen. Use these to connect a keyboard and mouse/trackball (optional).
- 4 (four) USB 2.0 ports (not supported) on the back of the main panel. Do not connect anything to these ports.

7 – Display (Unused)

- These two ports are not supported at this time. Do not connect anything to these ports.

8 – TRS (Unused)

- These 5 (five) TRS ports are not supported at this time. Do not connect anything to these ports.

9 – S/PDIF OUT (Unused)

- This S/PDIF OUT port is not supported at this time. Do not connect anything to this port.

Side Panel

The left side panel provides the two primary power connectors and one Ethernet connector.

See Chapter 2, “S6 Master Module Connections.”

Top Panel Controls and Displays

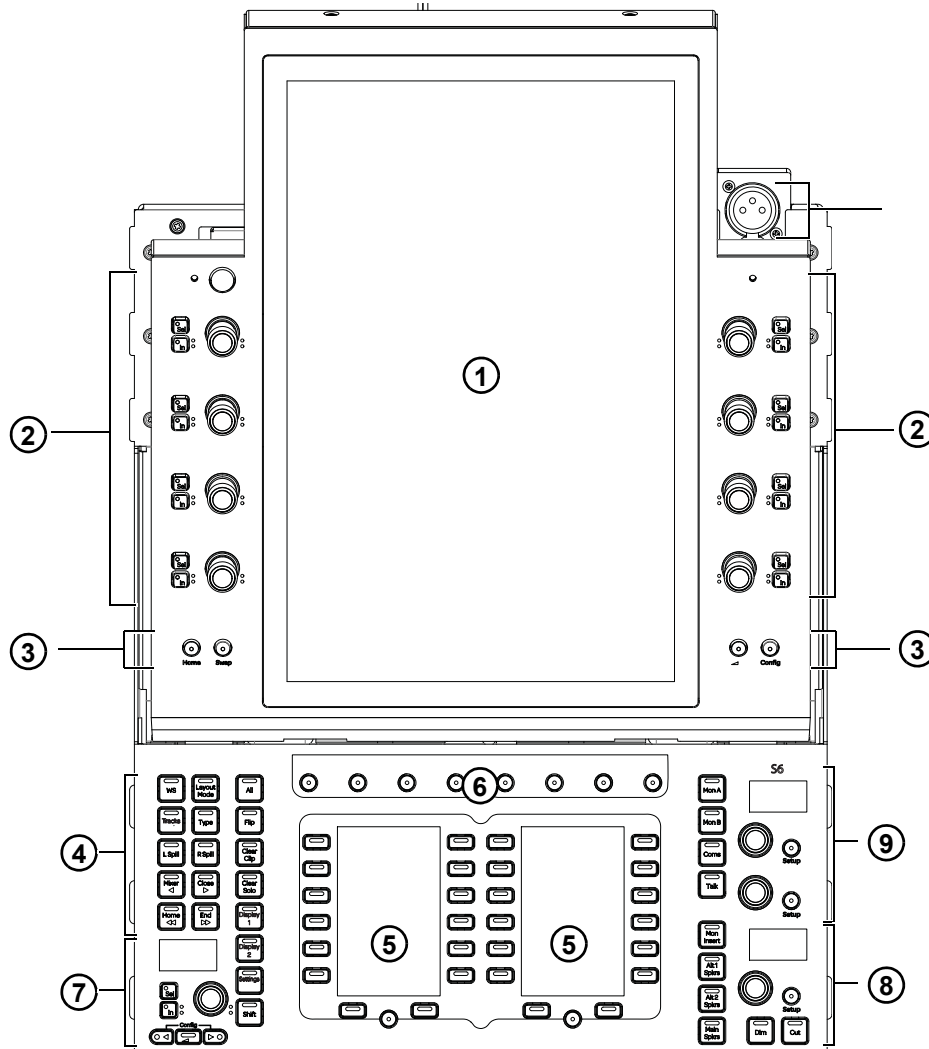

Top panel of the Master Module

- 1 - Touchscreen**
- 2 - Encoders**
- 3 - Home, Swap, Back, and Config**
- 4 - Navigation Switches**
- 5 - Soft Keys**
- 6 - Main Menu Switches**
- 7 - Custom Encoder**
- 8 - Studio/Talk Controls**
- 9 - Monitoring Controls**
- 10 - Talkback Mic Input**

1 — Touchscreen



Touchscreen

The Touchscreen is a 1280x800, multi-point TFT display.

Stand

The Touchscreen provides an attached stand that lets you set and secure the screen at the most desirable angle.

2 — Encoders

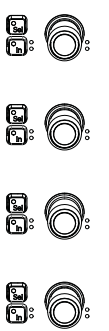

Encoders (4 of 8 shown)

Surrounding the Touchscreen are eight touch-sensitive, dual-function encoders (rotate and push functionality). The encoders light red, green, or blue depending on the current function and status.

Encoder Automation Indicator LEDs

Two Automation Indicators (red and green) are located next to the encoder.

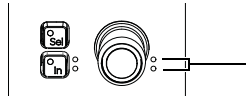

Encoder Automation indicator LEDs

Each encoder has the following controls and indicators.

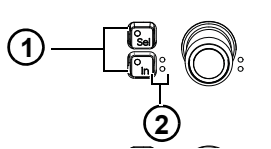

Encoder In and Sel switches (1), and Automation indicator LEDs (2)

In and Sel (Select) Each encoder has its own corresponding In and Sel switches. In lights green when enabled. Sel lights yellow when enabled.

Automation Indicators Two LEDs (red and green) for the In and Sel switches indicate automation status.

3 — Home, Swap, Back, and Config

Home and Swap are below the left set of encoders; < and Config are below the right set of encoders. These switches light red, green, or blue to indicate function and status.



Home (1) Swap (2) < (3) and Config (4)

Home Returns the Touchscreen to Home.

Swap This control is not implemented.

Back Returns the Touchscreen to the previous view.

Config This control is not implemented.

4 — Navigation Switches

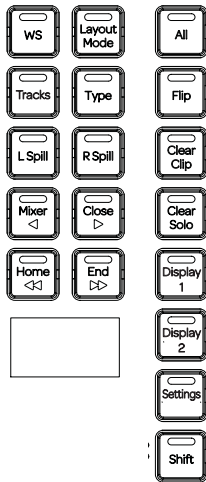

Navigation switches

WS Opens the Workstation Settings page.

Layout Mode Accesses the Layouts screen to store and recall track layouts.

All Enables linked function navigation.

Tracks Jumps to the Tracks page.

Type This control is not implemented.

Flip This control is not implemented.

L Spill This control is not implemented.

R Spill This control is not implemented.

Clear Clip Clears Clip (over) indicators.

◀ / Mixer Nudge left. **SHIFT+◀/Mixer** opens the Mix window.

▶ / Close Nudge right. **SHIFT+▶/Close** closes the Mix window.

Clear Solo Takes all currently soloed channels out of Solo mode.

◀◀ / Home Banks the surface left. **SHIFT+◀◀ / Home** banks so that track 1 appears on fader strip 1 (left-justified).

▶▶ / End Banks the surface right. **SHIFT + ▶▶ / End** banks so that the last track appears on the last fader strip (right-justified).

Display 1 Zooms the Display Module Waveform view out 10 seconds. (Hold **Shift** on the Master Module while pressing **Display 1** to zoom out 1 second.)

Display 2 Zooms the Display Module Waveform view in 10 seconds. Hold **Shift** on the Master Module while pressing **Display 1** to zoom in 1 second.)

Settings Jumps to the Settings page.

Shift When held, accesses secondary functions of other switches.

5 — Soft Keys

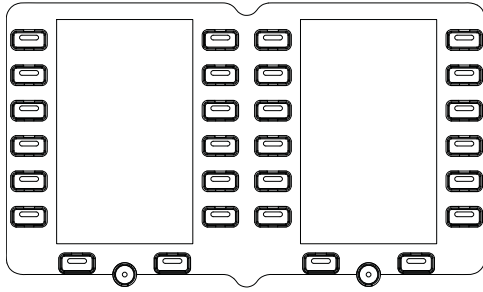

Soft Keys screens

The Master Module provides two 12-key Soft Key banks, each with its own TFT display. Below each bank are three additional Soft Keys that by default let you navigate to previous/next pages of Soft Keys.

6 — Main Menu Switches



Main Menu switches

These switches provide physical controls for the functions listed directly above them (across the bottom of the Touchscreen). The Main Menu switches light yellow when active.

7 — Custom Encoder

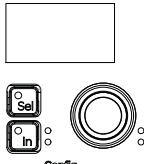

Custom encoder

The Custom Encoder is an assignable dual-function encoder (rotate and press functionality) with its own OLED display. The encoder lights in different colors to indicate function and status. Two Automation Indicators (red and green) are next to the encoder.

The Custom Encoder has the following controls and indicators.

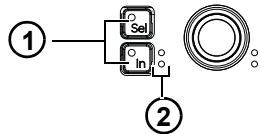

Encoder In and Sel switches (1), and Automation indicator LEDs

In and Sel (Select) **In** lights green when enabled. **Sel** lights yellow when enabled.

Automation Indicators Two LEDs (red and green) for the **In** and **S** switches indicate automation status.

8 — Studio/Talk Controls and Display

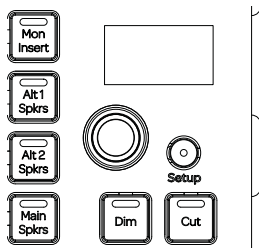

Studio/Talk controls and display

The Studio/Talk section provides controls for control room monitoring, speaker selection, and talkback. It includes one touch-sensitive, multi-color encoder that lights to indicate function and status, and a 128x64 OLED display and the following switches.

Setup Accesses the Monitoring Setup screen to customize the behavior of the other Studio/Talk controls.

Mon Insert

Alt 1 Spkrs Selects Alt 1 Speakers.

Alt 2 Spkrs Selects Alt 2 Speakers.

Main Spkrs Selects Main Speakers.

Dim Dims the studio monitor level by the current Dim amount.

Cut Mutes the speaker outputs.

9 — Monitor Controls and Display

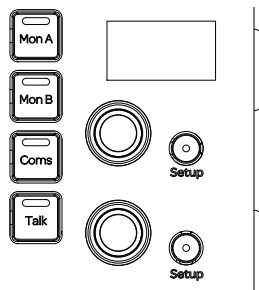

Monitoring Control switches

This section includes two touch-sensitive, multi-color encoders that light to indicate function and status. The Monitoring section also provides a 128x64 OLED display and the following switches.

Setup (x2) The upper **Setup** switch locks the monitoring section to the current application. The lower Setup switch opens the Monitor Setup screen.

St A Rotating controls Monitor A level; pressing mutes Monitor A.

St B Rotating controls Monitor B level; pressing mutes Monitor B.

Coms This control is not implemented.

Talk Activates Talkback.

10 — Talkback In

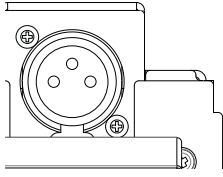

Talkback In (XLR)

One XLR F (female) input is provided on the top panel, above and to the right of the Touchscreen, for connecting a gooseneck microphone for Talkback.

Appendix A: Specifications

Mechanical

Avid S6 Master Module Mechanical Specifications

Parameter	Specification
Dimensions (L x W x D)	19.7 x 11.6 x 2.4 inches (+ 0.7 inches including knobs) 500 x 294 x 60 mm (+ 17mm including knobs)
Weight	15.4 lbs (7 kg)
Power Requirements	12 VDC, 6.7 A
Ethernet Ports (2)	1000-BaseT (Gigabit) Ethernet RJ-45
USB Ports	USB 2.0
GPI	General Purpose Interface I/O, on one D-Type connector

Environmental

Avid S6 Master Module Environmental Specifications

Parameter	Specification	Limit	Units	Condition/Comment
Storage Temperature	-18 to +60 deg C		deg C	0 to +140 deg F
Operating Temperature	+4 to +40 deg C		deg C	+40 to +104 deg F
Storage humidity range	5 to 95		%	Non-condensing
Operating Humidity Range	20 to 80		%	Non-condensing
Continuous Vibration (Storage only: non-powered transportation)	1		g RMS	Random spectrum

Dimensions

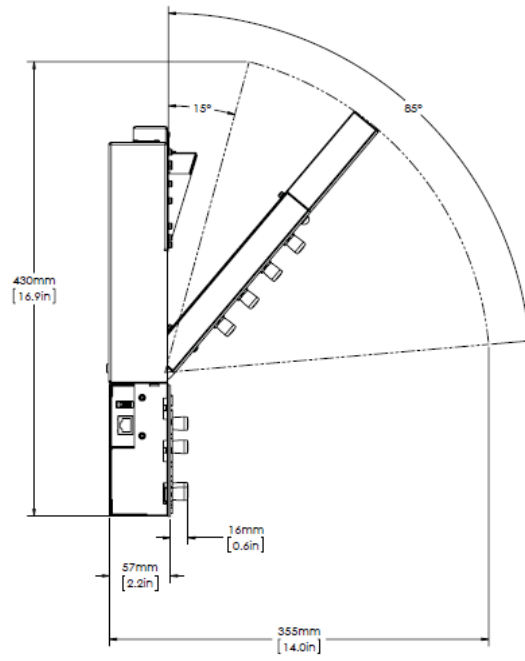
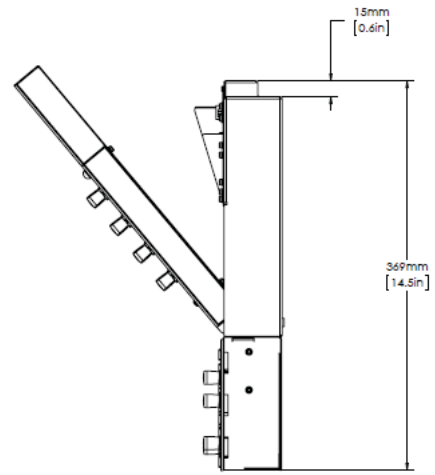
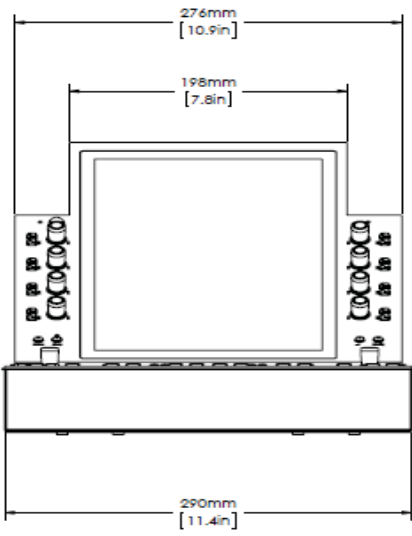

Appendix B: Compliance Information

Environmental Compliance

Disposal of Waste Equipment by Users in the European Union



This symbol on the product or its packaging indicates that this product must not be disposed of with other waste. Instead, it is your responsibility to dispose of your waste equipment by handing it over to a designated collection point for the recycling of waste electrical and electronic equipment. The separate collection and recycling of your waste equipment at the time of disposal will help conserve natural resources and ensure that it is recycled in a manner that protects human health and the environment. For more information about where you can drop off your waste equipment for recycling, please contact your local city recycling office or the dealer from whom you purchased the product.

Proposition 65 Warning

▲ *This product contains chemicals, including lead, known to the State of California to cause cancer and birth defects or other reproductive harm. Wash hands after handling.*

Perchlorate Notice

This product may contain a lithium coin battery. The State of California requires the following disclosure statement: “Perchlorate Material – special handling may apply, See [www.dtsc.ca.gov/hazardous waste/perchlorate](http://www.dtsc.ca.gov/hazardous%20waste/perchlorate).”

Recycling Notice



EMC (Electromagnetic Compliance)

Avid declares that this product complies with the following standards regulating emissions and immunity:

- FCC Part 15 Class B
- EN 55022 Class B
- AS/NZS CISPR 22 Class B
- CISPR 22 Class B
- EN 55103-1, Class E2 and E3
- EN 55103-2, Class E2 and E3

FCC Compliance for United States

Communication Statement

NOTE: This equipment has been tested and found to comply with the limits for a Class B digital device, pursuant to Part 15 of the FCC Rules. These limits are designed to provide reasonable protection against harmful interference in a residential installation. This equipment generates, uses, and can radiate radio frequency energy and, if not installed and used in accordance with the instructions, may cause harmful interference to radio communications. However, there is no guarantee that interference will not occur in a particular installation. If this equipment does cause harmful interference to radio or television reception, which can be determined by turning the equipment off and on, the user is encouraged to try and correct the interference by one or more of the following measures:

- Reorient or locate the receiving antenna.
- Increase the separation between the equipment and receiver.
- Connect the equipment into an outlet on a circuit different from that to which the receiver is connected.
- Consult the dealer or an experienced radio/TV technician for help.

Any modifications to the unit, unless expressly approved by Avid, could void the user's authority to operate the equipment.

Australian Compliance



Canadian Compliance

This Class B digital apparatus meets all requirements of the Canadian Interference-Causing Equipment Regulations.

Cet appareil numérique de la classe B respecte toutes les exigences du Règlement sur le matériel brouilleur du Canada.

CE Compliance

(EMC and Safety)



Avid is authorized to apply the CE (Conformité Européenne) mark on this compliant equipment thereby declaring conformity to EMC Directive 2004/108/EC and Low Voltage Directive 2006/95/EC.

Safety Compliance

Safety Statement

This equipment has been tested to comply with USA and Canadian safety certification in accordance with the specifications of UL Standards: UL 60065 7th Ed., 2007-12-11, CAN/CSA C22.2 No. 60065-03, 1st Ed, 2006-04 +A1:2006, EN 60065:2002 + A1:2006 + A11:2008, IEC 60065:2001 + A1:2005 + A2:2010.

Avid Technology Inc., has been authorized to apply the appropriate NRTL mark on its compliant equipment.

Korea Class B EMC Compliance

이 기기는 가정용 (B 급) 전자파적합기기로서 주로 가정에서 사용하는 것을 목적으로 하며, 모든 지역에서 사용할 수 있습니다.

Warning



Important Safety Instructions

- 1) Read these instructions.
- 2) Keep these instructions.
- 3) Heed all warnings.
- 4) Follow all instructions.
- 5) Do not use this equipment near water.
- 6) Clean only with dry cloth.
- 7) Do not block any ventilation openings. Install in accordance with the manufacturer's instructions.
- 8) Do not install near any heat sources such as radiators, heat registers, stoves, or other equipment (including amplifiers) that produce heat.
- 10) Protect power cords from being walked on or pinched particularly at plugs, convenience receptacles, and the point where they exit from the equipment.
- 11) Only use attachments/accessories specified by the manufacturer.
- 12) For products that are not rack-mountable: Use only with a cart, stand, tripod, bracket, or table specified by the manufacturer, or sold with the equipment. When a cart is used, use caution when moving the cart/equipment combination to avoid injury from tip-over.
- 13) Unplug this equipment during lightning storms or when unused for long periods of time.
- 14) Refer all servicing to qualified service personnel. Servicing is required when the equipment has been damaged in any way, such as power-supply cord or plug is damaged, liquid has been spilled or objects have fallen into the equipment, the equipment has been exposed to rain or moisture, does not operate normally, or has been dropped.

15) For products that are a Mains powered device:

The equipment shall not be exposed to dripping or splashing and no objects filled with liquids (such as vases) shall be placed on the equipment.

Warning! To reduce the risk of fire or electric shock, do not expose this equipment to rain or moisture.

Do not defeat the safety purpose of the polarized or grounding-type plug. A polarized plug has two blades with one wider than the other. A grounding type plug has two blades and a third grounding prong. The wide blade or the third prong are provided for your safety. If the provided plug does not fit into your outlet, consult an electrician for replacement of the obsolete outlet.

16) For products containing a lithium battery:

CAUTION! Danger of explosion if battery is incorrectly replaced. Replace only with the same or equivalent type.

17) For products with a power switch:

It should remain accessible after installation.

18) The equipment shall be used at a maximum ambient temperature of 40° C.

19) This unit is provided with a power supply cord set suitable for 120V AC input only (for U.S.A. and Canada). For other than U.S.A. and Canada, a qualified person must provide for use with this unit, an appropriate, approved power supply cord set which is in compliance with the end use country requirements and has a minimum cross-sectional area of 1.0mm².

20) For products with more than one power cord:

CAUTION: This unit has more than one power supply cord. Disconnect two power supply cords before servicing to avoid electrical shock.

ATTENTION: Cet appareil comporte plus d'un cordon d'alimentation. Afin de prévenir les chocs électriques, débrancher les deux cordons d'alimentation avant de faire le dépannage.

21) For products with an operator-accessible fuse:

CAUTION: For continued protection against risk of fire, replace only with same type and rating of fuse.

ATTENTION: Pour ne pas compromettre la protection contre les risques d'incendie, remplacer par un fusible de même type et de même caractéristiques nominales.



Avid
2001 Junipero Serra Boulevard
Daly City, CA 94014-3886 USA

Technical Support (USA)
Visit the Online Support Center at
www.avid.com/support

Product Information
For company and product information,
visit us on the web at www.avid.com